



www.freewing-model.com

SR-71 BLACKBIRD

USER MANUAL

WINGSPAN:960MM(37.8") LENGTH:1896MM (74.6")
EMPTY WEIGHT:3560G (W/O BATTERY)



TWIN 70MM EDF JET

 **FreewingGuard 6-Axis Gyro**
PNP with Gyro Version



EN	1~12
中	13~24

- 1 Introduction
- 2 Product Basic Information
- 2 Package list
- 3 PNP Assembly Instructions
- 3 Install Fuselage
- 4 Install Main Wing
- 4 Install Vertical Tail
- 5 Install Nose Cone
- 6 Battery Instructions
- 6 Pushrod Instructions
- 7 Center of gravity
- 8 Control Board Introduction
- 9 Control Direction Test
- 10 Dual Rates
- 11 Center position of aileron
- 12 Servo Direction
- 12 Motor Specification

Note:

- 1.This is not a toy! Operator should have a certain experience, beginners should operate under the guidance of professional players.
- 2.Before install, please read through the instructions carefully and operate strictly under instructions.
- 3.Cause of wrong operation, Freewing and its vendors will not be held responsible for any losses.
- 4.Model planes' players must be on the age of 14 years old.
- 5.This plane used the EPO material with surface spray paint, don't use chemical to clean, otherwise it will damage.
- 6.You should be careful to avoid flying in areas such as public places, high-voltage-intensive areas, near the highway, near the airport or any other place where laws and regulation clearly prohibit.
- 7.You cannot fly in bad weather conditions such as thunderstorms, snows....
- 8.Model plane's battery, don't allowed to put in everywhere. Storage must ensure that there is no inflammable and explosive materials in the round of 2M range.
- 9.Damaged or scrap battery should be properly recycled, it can't discard to avoid spontaneous combustion and fire.
- 10.In flying field, the waste after flying should be properly handled, it can't be abandoned or burned.
- 11.In any case, you must ensure that the throttle is in the low position and transmitter switch on, then it can connect the lipo-battery in aircraft.
- 12.Do not try to take planes by hand when flying or slow landing process. You must wait for landing stop, then carry it.

⚠ NOTE: This is not a toy. Not for children under 14 years. Young people under the age of 14 should only be permitted to operate this model under the instruction and supervision of an adult. Please keep these instructions for further reference after completing model assembly.

Thank you for purchasing our Freewing twin 70mm EDF super scale jet, SR-71 Blackbird. Before you assemble this SR-71 model jet, please carefully read the instructions and follow the correct process for assembly and adjustment. If you encounter problems during assembly and debugging, please first resolve them by referring to the instructions. If the problem persists, please contact the distributor or directly contact us.

The Freewing SR-71 Blackbird electric ducted model jet uses EPO material, length is 1896mm, wing span is 960 mm with contour simulation, black matte paint surface coating^①, and exquisite engraved lines. The fuselage has been labeled with basic universal warning signs at factory and three sets of stickers with different schemes are additionally given as gifts. The entire model is roughly divided into four parts, namely: front fuselage, rear fuselage, main wing, and vertical tail. These four parts are assembled using screws for fixation. The front fuselage uses a large number of plastic parts to protect the sharp spine of the front fuselage, while ensuring the height restoration of the appearance. Inside the front and rear fuselage, a large number of carbon fiber pipes are embedded to reinforce the fuselage and ensure structural strength.

The Freewing SR-71 Blackbird PNP version is equipped with two sets of 70mm 12 blade EDF power systems (2957-2210KV in-runner motor, 80A ESC). The dual battery compartment distributed in the front and rear fuselage adopts a through design, which brings us a very flexible battery matching solution: from one pcs 6000mAh battery to two pcs 4500mAh batteries, they can all be placed in the battery compartment in order to obtaining longer flight time^②.

Through design optimization, flight performance tuning, and the assistance of the Freewing Guard Gyro[®], we have significantly reduced the flight difficulty of this SR-71 "Blackbird" model jet, making it easier to control. Its takeoff distance is about 35 meters and its maximum level flight speed is about 170KPH. During the flight, the attitude is stable, and the action response is fast and precise. It can perform routine flight movements such as rolling, flying backwards, and loops. In the low-speed range, it maintains a stable attitude without obvious left or right leaning.

The Freewing SR-71 Blackbird model jet includes a brake parachute^③. After landing on the ground, releasing the parachute through the switch has a significant deceleration effect and shortens the ground taxiing distance.

Thank you again. I hope this new SR-71 Blackbird model jet can bring you a better experience. I wish you a successful flight!

Notes:

①EPO materials undergo swelling and bubbling reactions at around 60 °C. This product has a black matte paint surface with strong heat absorption ability, which rapidly increases the surface temperature. When flying the SR-71 model jet outdoors: a, avoid flying during periods of high temperature. b. When debugging the jet, please do it under a sunshade to avoid direct sunlight; c. Try to shorten the ground taxiing time as much as possible, take off as soon as possible, and recover as soon as possible; d. The jet needs to be placed in a shaded area under a sunshade to avoid direct sunlight. e. We do not assume any responsibility for surface blistering caused by negligence in protection, exposure of products to sunlight, or high temperature radiation heating in hot weather environments.

②Different brands of batteries have varying sizes, and this data was obtained from testing Admiral batteries as samples.

When conducting a cruise test with a single Admiral 6S 5000mAh 50C battery, the flight duration is 2 minutes and 20 seconds with 40% full throttle and 60% high throttle lever.

③The Freewing SR-71 PNP version pre-installed with the Freewing Guard Gyro (standard version) at factory, which has been loaded with dedicated flight data. Please switch the channel switch and confirm that the gyro is in a constant green indicator light before starting the flight.

④Whether the parachute can be successfully deployed depends on the jet's taxiing speed and the folding state of the parachute bag.

After landing on ground, if the jet slides slowly, the parachute may not be able to deploy smoothly.

The folding method of the parachute bag is incorrect, and the parachute may not be able to unfold smoothly. Please refer to the official assembly video to learn how to fold the parachute.

After each parachute landing, the brake parachute needs to be folded again and placed in the parachute compartment.

Standard Version

Wingload: 72g/dm²
 Wing Area: 60dm²
 Servo: 9g Hybrid Digital Servos (2pcs)
 9g Digital Plastic Gear Servos (3pcs)
 17g MG Digital Servo (4pcs)
 23g MG Digital Servo (2pcs)
 Motor: 2957-2210KV I/R Motor
 Ducted fan: 70mm 12-blade fan
 ESC: Dual 80A Brushless ESC(10A UBEC)
 Weight: 3560g(w/o Battery)

Other Notes

Landing gear: Electric landing gear
 Li-Po Battery: 6S 5000-7000mAh
 Cabin doors: front and rear complete
 cabin doors, servo control
 Other: parachute

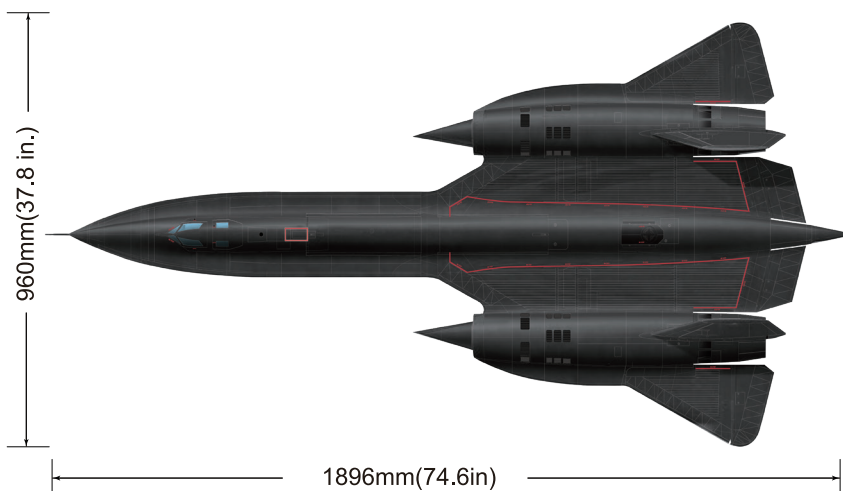

⚠ Note: The parameters in here are derived from test result using our accessories. If use other accessories, the test result will be different. Any problem since of using other accessories, we are not able to provide technical support.

Package List

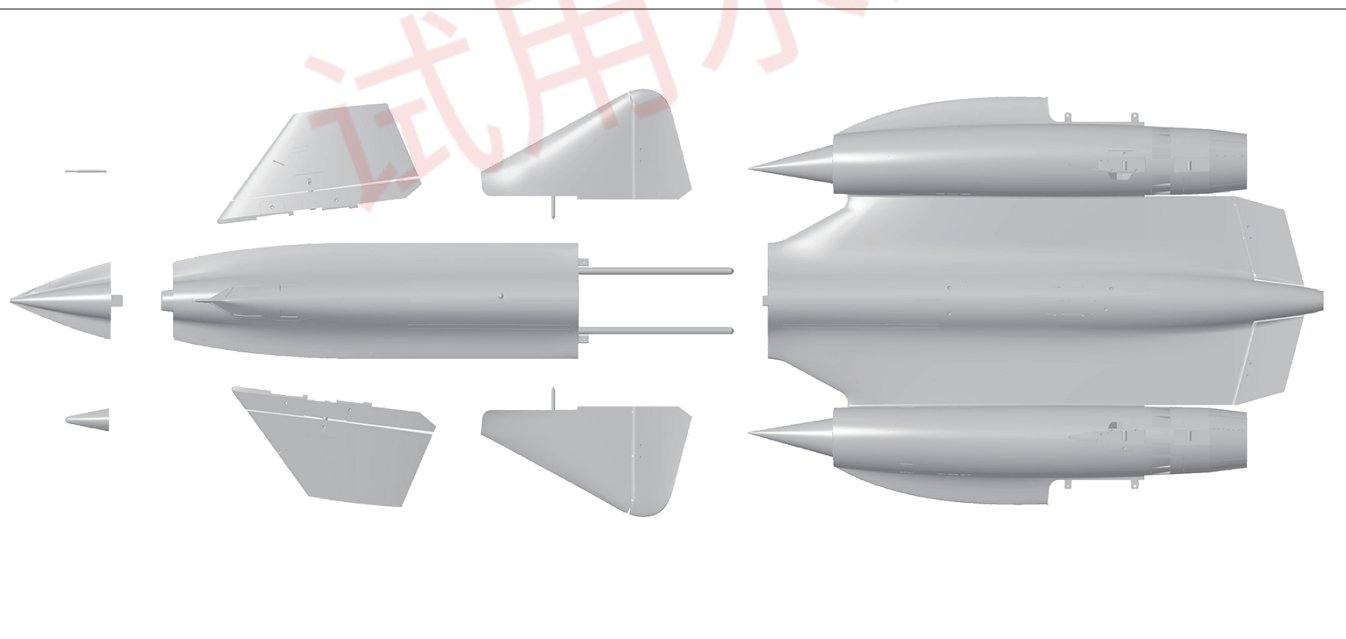

Different equipment include different spareparts. Please refer to the following contents to check your sparepart list.

No.	Name	PNP	ARF Plus
1	Fuselage	Pre-installed all electronic parts	Pre-installed servo
2	Front fuselage	Pre-installed all electronic parts	Pre-installed servo
3	Main wing	Pre-installed all electronic parts	Pre-installed servo
4	Vertical tail	Pre-installed all electronic parts	Pre-installed servo
5	Nose cone	✓	✓

No.	Name	PNP	ARF Plus
6	Cockpit	✓	✓
7	Landing gear	✓	✓
8	Annex bag	✓	✓
9	Manual	✓	✓

Install Fuselage

As the photo show:

1. Use glue to fix the guide cones onto the two carbon tubes at the front fuselage.
2. Align the carbon tube of the front fuselage with the rear fuselage, remove the ribbon cable from the rear fuselage, connect it to the front fuselage ribbon socket (connect the front and rear fuselage cables), and install the front fuselage into the rear fuselage;

Screw (KM 3*7mm 3PCS)

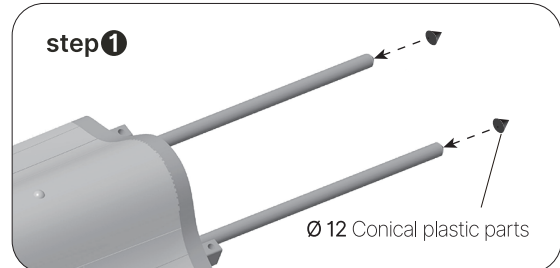
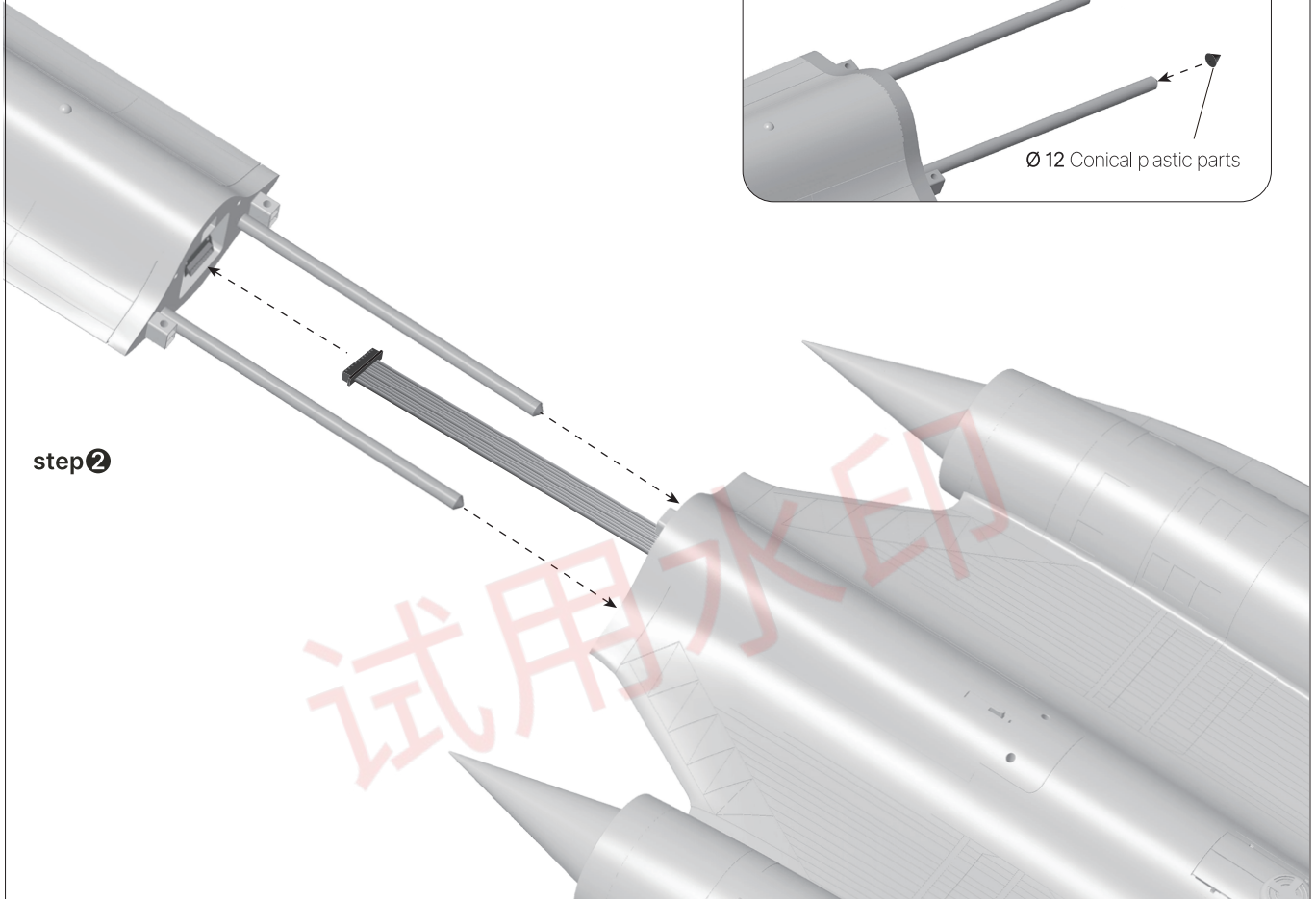

3. As shown in step 3, tighten with screws.

4. As shown in step 4, turn over the fuselage and tighten it with screws.

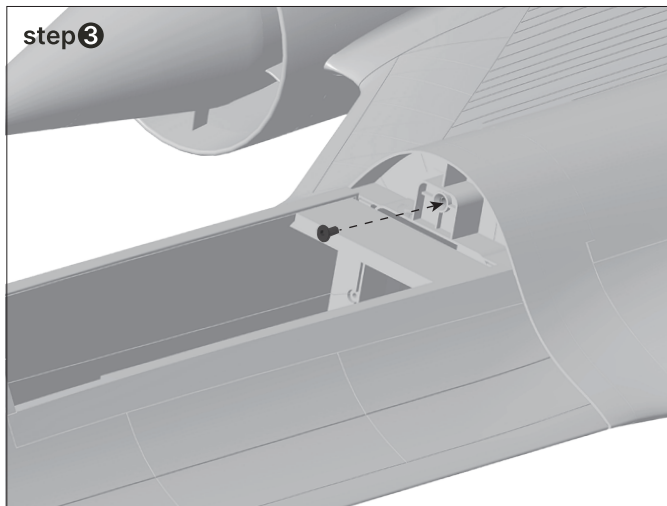

Install Main Wing

As the photo show:

1. Use glue to fix the guide cone onto the main wing carbon tube;
2. Align the main wing carbon tube with the fuselage, remove the servo extension cable from one end of the fuselage, insert it into the main wing servo extension cable interface, and push the main wing into the installation position on the fuselage;
3. Then tighten with screws. (Repeat this step for the other main wing)

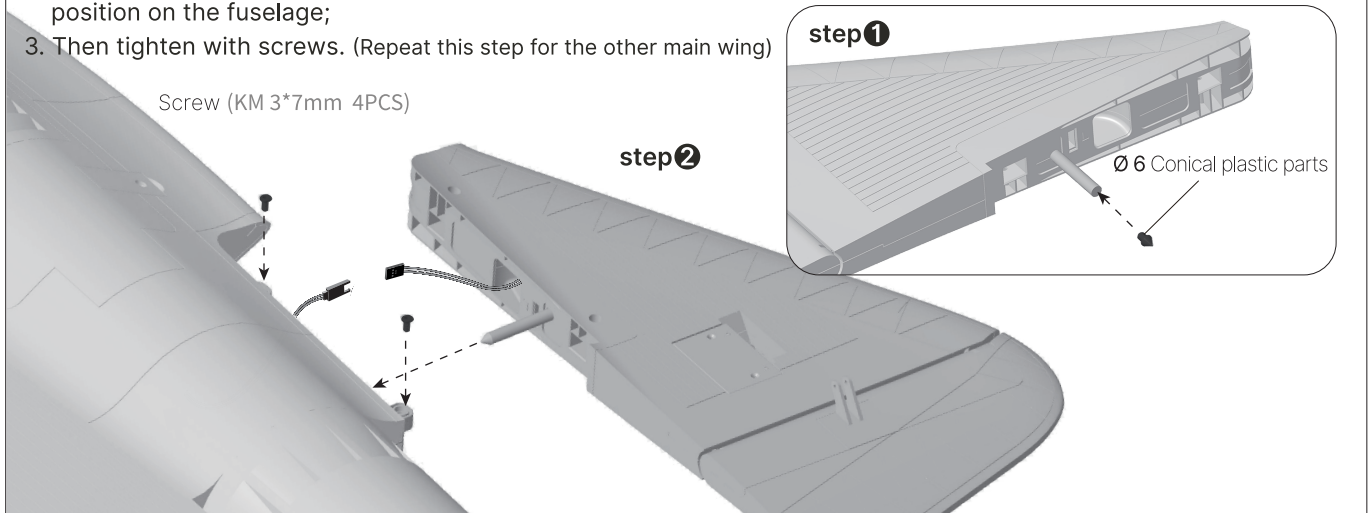

Install Vertical Tail

1. Align the vertical tail with the fuselage and push it into the installation position on the fuselage
2. Then tighten with screws;
3. Install the ball link onto the ball buckle of pushrod, and install the pushrod onto servo arm and vertical horn, fixing them with screws. (Repeat this step on the other vertical tail)

Screw (KM 3*7mm 8PCS)
(PM 2*10mm 2PCS)

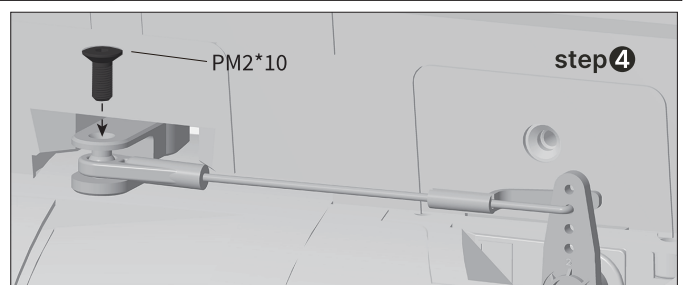
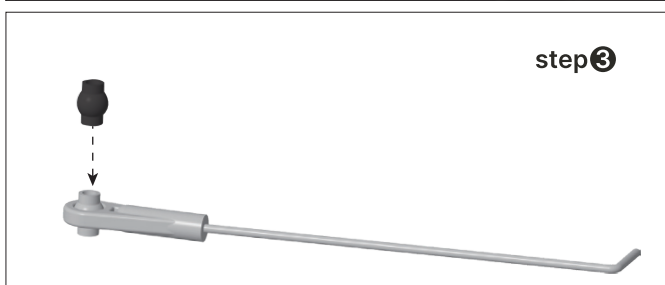
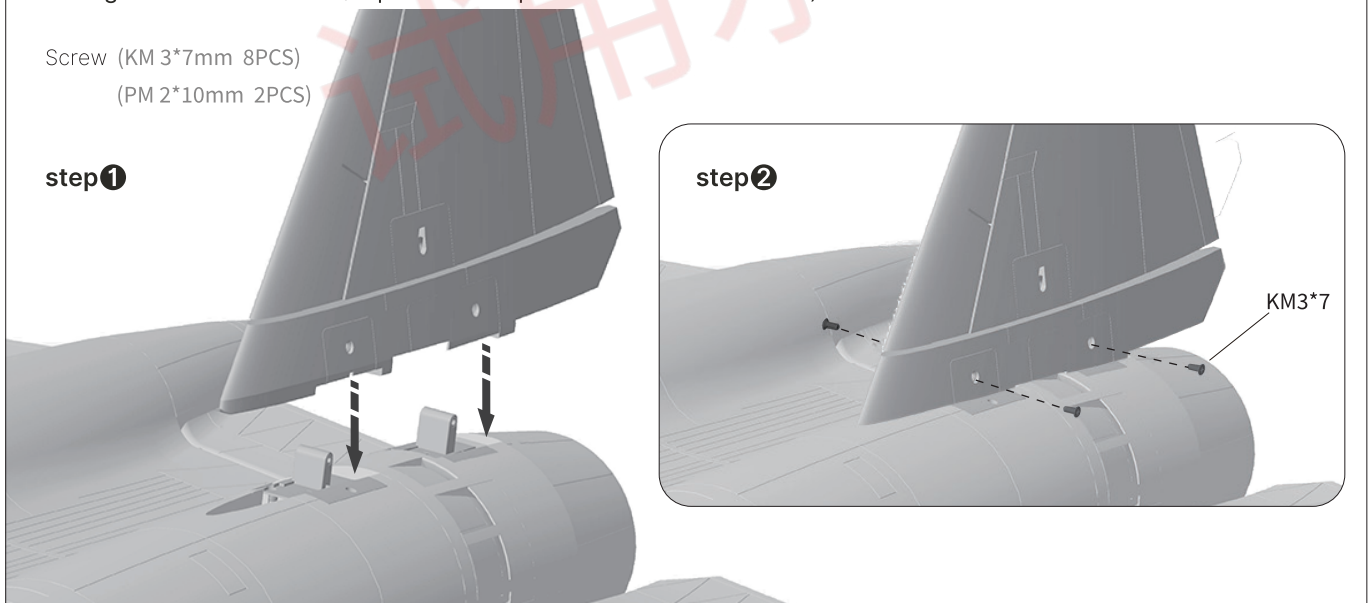

Install nose cone

As the photo show:

1. Insert the airspeed tube directly into the nose cone;
2. Install the nose cone onto the fuselage

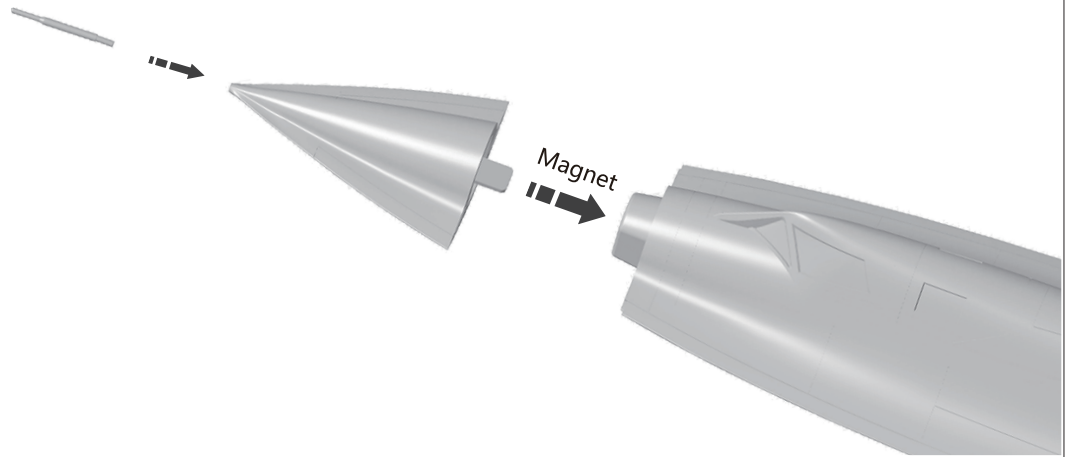
**Install tail cone**

As the photo show:

1. Install the tail cone onto the fuselage.

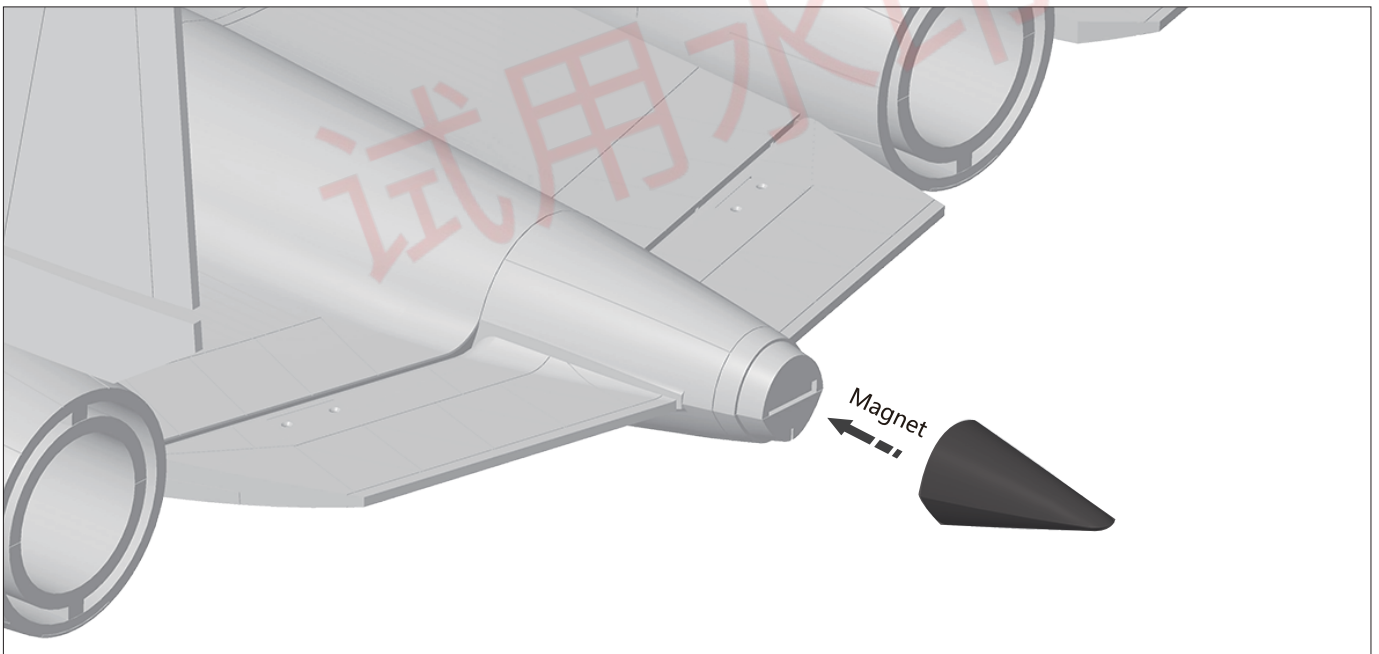
**Important additional notes**

The Y-type clevis used in this product is equipped with a transparent silicone ring for secondary reinforcement, which can effectively prevent the clevis from accidentally loosening.

As shown in the following figure, when you buckle the clevis into the control surface horn, use the silicone ring to cover the clevis.

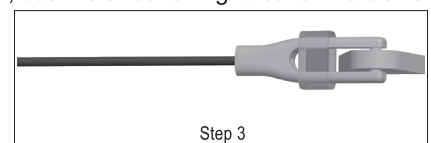
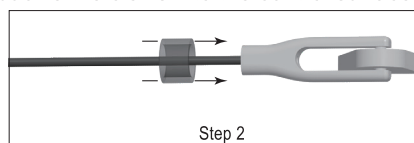
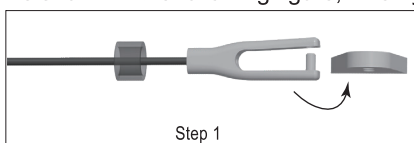

Install Battery

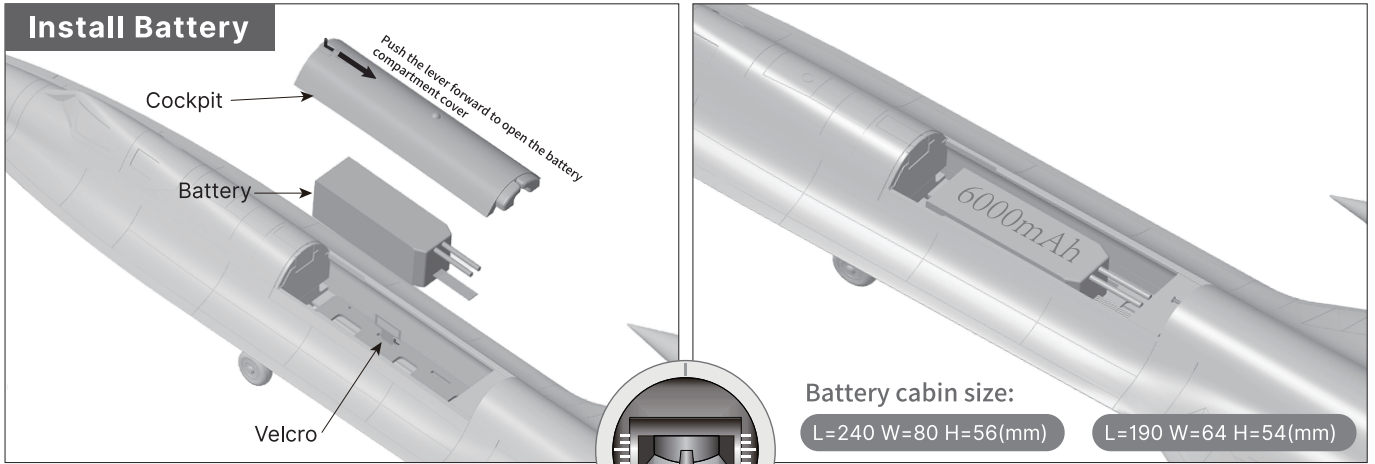

Before connecting the battery and receiver, please switch on the transmitter power and make sure the throttle stick is in the lowest position. Bind your receiver to your transmitter according to your transmitter's instruction manual.

Battery cabin size:

L=240 W=80 H=56(mm)

L=190 W=64 H=54(mm)

We recommend the following LiPo battery:
6S 22.2V 5000mAh~6S 22.2V 7000mAh (1pcs)
 Discharge rate of C ≥35C

Pushrod Instructions

Aileron pushrod length (Outer-side)

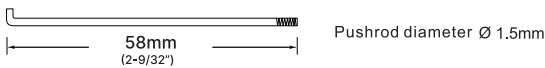

Aileron pushrod mounting hole (Outer-side)



Rudder pushrod length

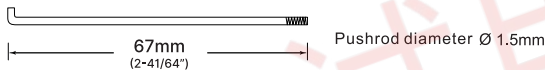

Rudder pushrod mounting hole

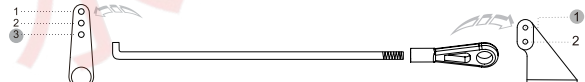

Aileron pushrod length (In-side)

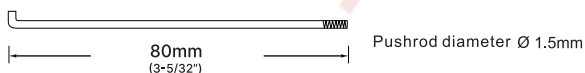

Aileron pushrod mounting hole (In-side)



Nose Cabin door pushrod length



Nose Cabin door pushrod mounting hole

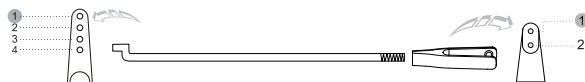

Rear cabin door pushrod length

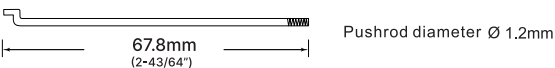

Rear cabin door pushrod mounting hole



Rear follow cabin door pushrod length



Rear follow cabin door pushrod mounting hole

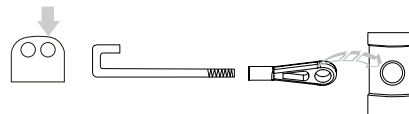

Nose gear steering pushrod length



Nose gear steering pushrod mounting hole



Flight notes

**Note:**

2. SR-71 needs to fly with gyro; Please use app versions V2.0.0 and above to set gyro parameters.
3. The brake parachute comes with a mis-operation protection program. When retracting the landing gear, the parachute cannot be opened. It can only be opened normally when the landing gear is opened!

Center of Gravity

Correct Center of Gravity ("CG") is critical for enabling safe aircraft stability and responsive control. Please refer to the following CG diagram to adjust your aircraft's Center of Gravity.

- Depending on the capacity and weight of your chosen flight batteries, move the battery forward or backward to adjust the Center of Gravity.
- If you cannot obtain the recommended CG by moving the battery to a suitable location, you can also install a counterweight to achieve correct CG. However, with the recommended battery size, a counterweight is not required. We recommend flying without unnecessary counterweight.

As the photo show, We marked the center of gravity on the bottom of the Main wing. Please confirm the CG based on this marked position.

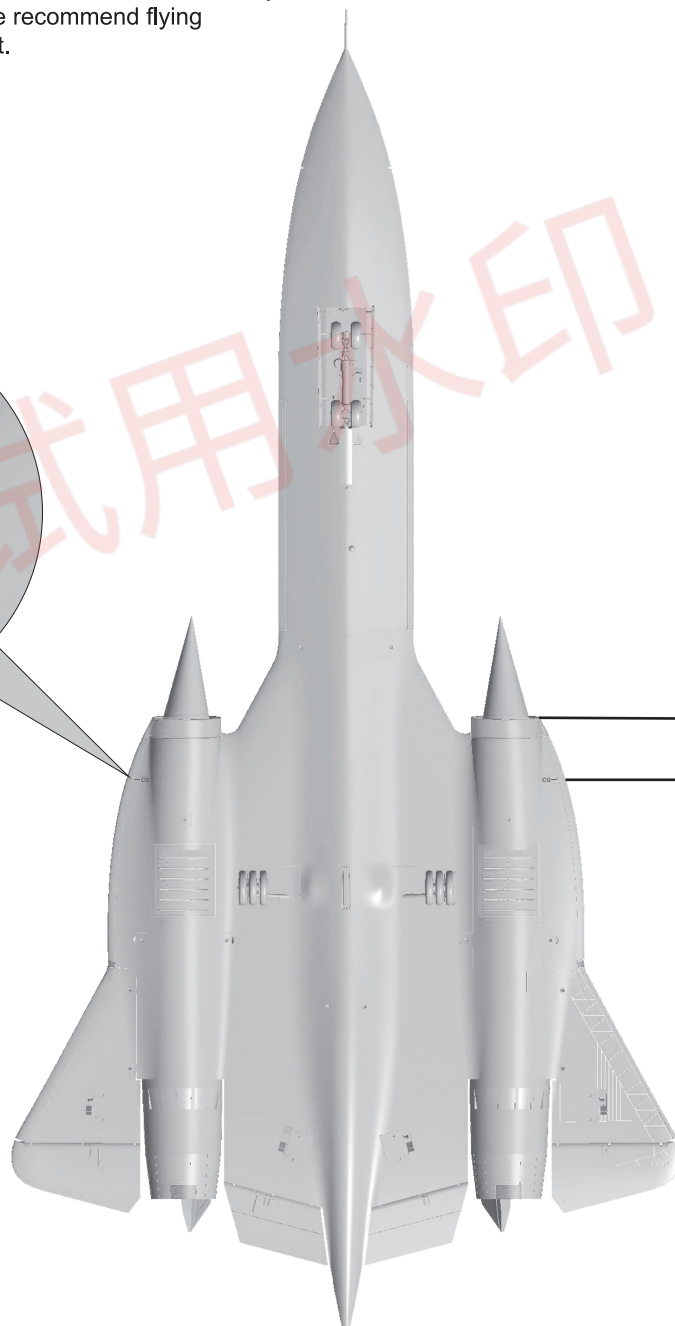
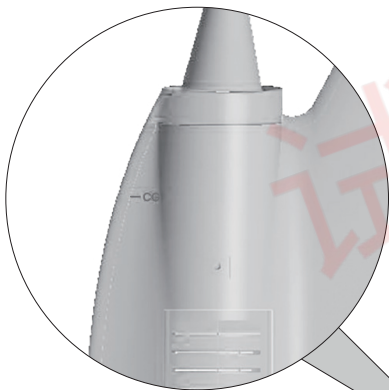

CG 90mm

Please refer to the diagram, connect the servo cables to the control board, and connect to the receiver correctly.

- ⚠ **Note:** 1. Ensure that each connecting cable is connected in the correct positive and negative directions;
 2. Ensure that the connecting cable is fully inserted into the row pin without loose;

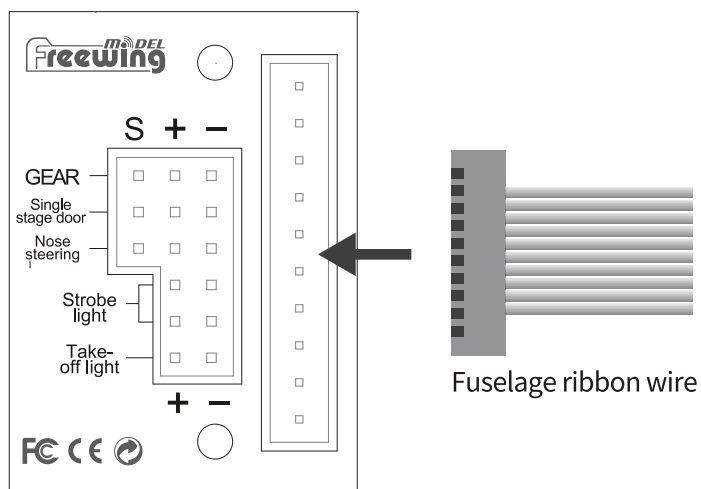
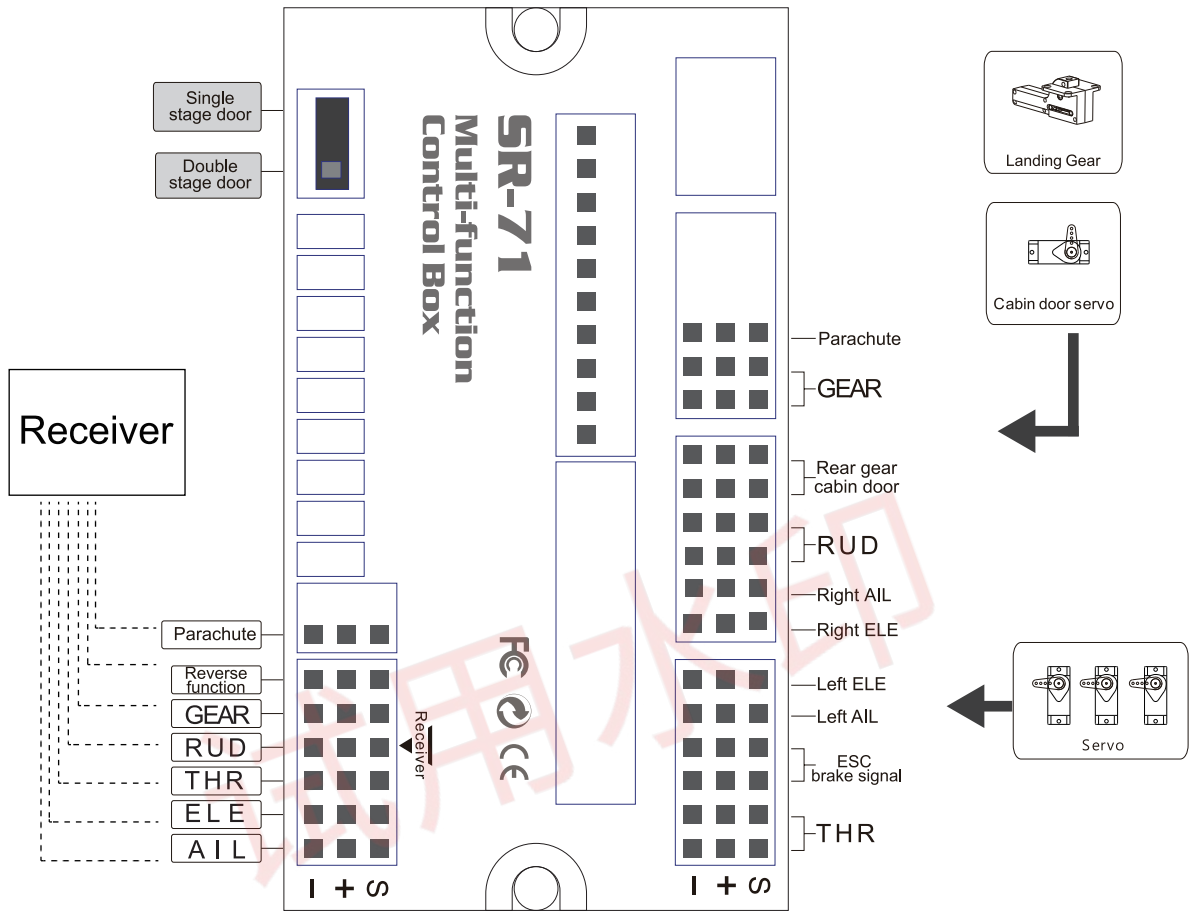

After installed this SR-71 model plane, please connect to the receiver and power on, then adjust it.

1. When all channels of radio are fine tuned to zero and the control stick is centered: check whether each control surface on the aircraft is in the center position. If it is found that the control surface is not in the center position, please adjust the control rod to center it;

2. Please refer to the diagram below and use the radio to test each control surface to ensure that its movement direction matches the diagram. If the opposite movement occurs, first check whether the relevant channel in the radio has enabled the reverse function; If the problem persists, please contact us for assistance in resolving it.

Aileron

Stick Left

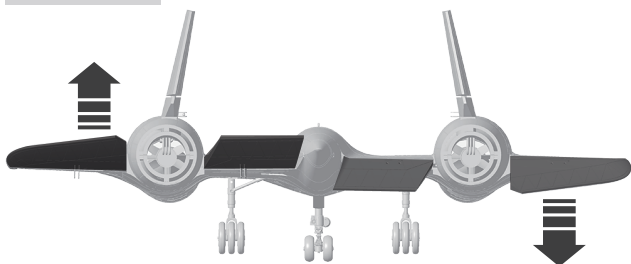

Stick Right

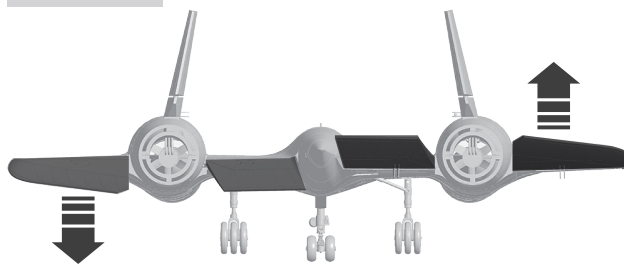

Rudder

Stick Left

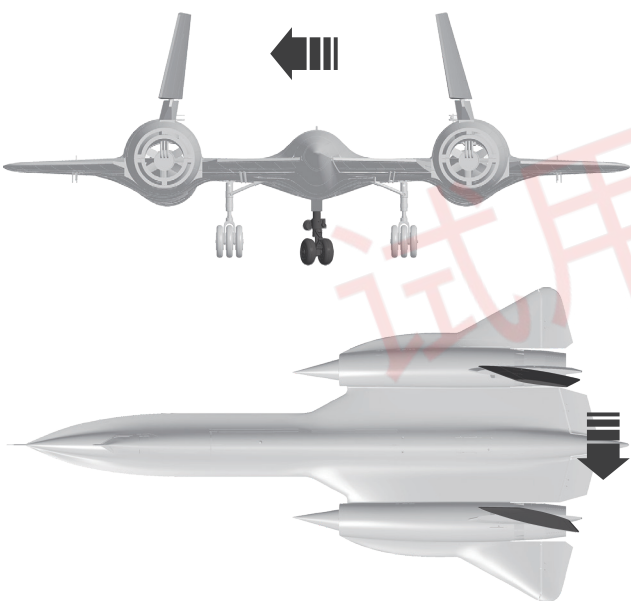

Stick Right

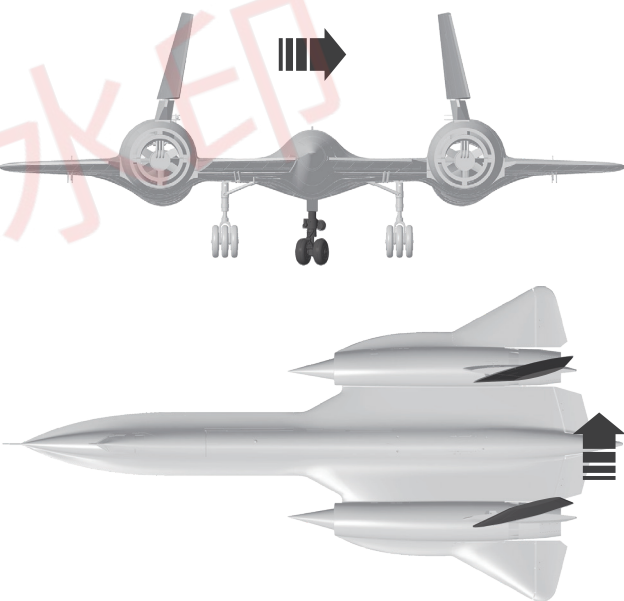

Elevator

Stick down

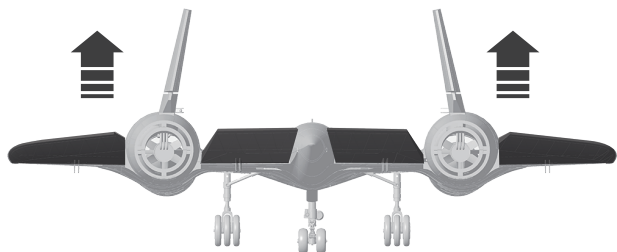

Stick up

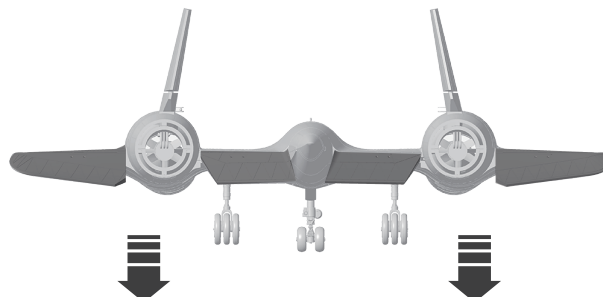

Dual Rates

According to our testing experience, use the following parameters to set Aileron/Elevator Rate. Program your preferred Exponential % in your radio transmitter. We recommend using High Rate for the first flight, and switching to Low Rate if you desire a lower sensitivity. On successive flights, adjust the Rates and Expo to suit your preference.

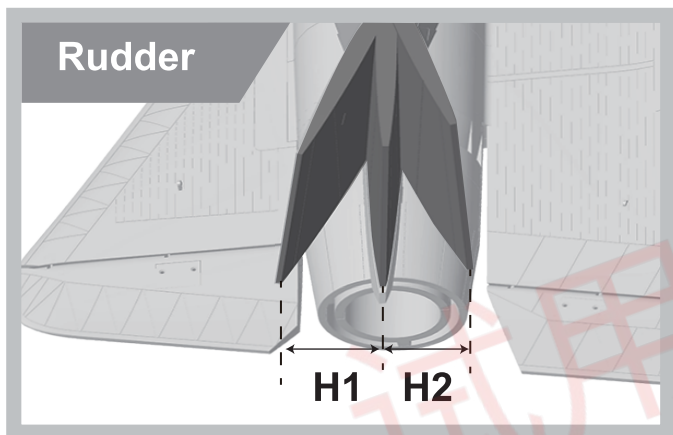
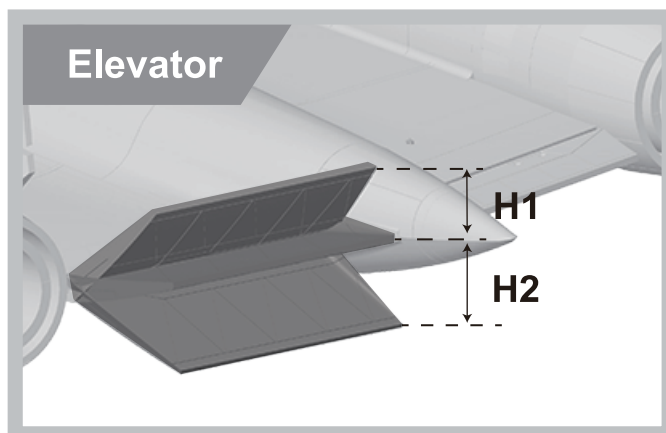
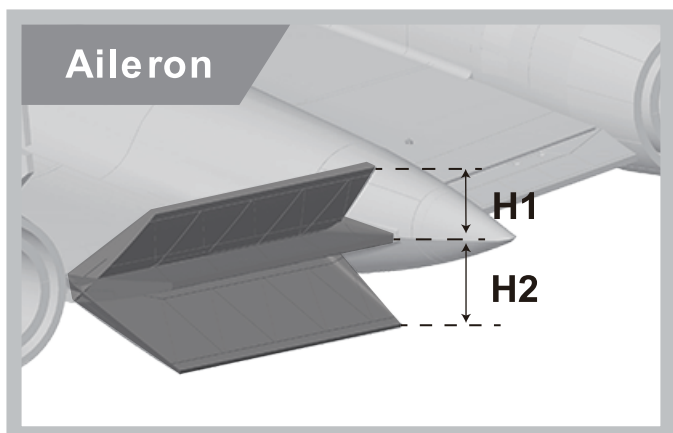

	Aileron <small>In-side</small> (Measured closest to the fuselage)	Elevator <small>In-side</small> (Measured closest to the fuselage)	Rudder (Measured from the bottom)
Low Rate	H1/H2 18mm/18mm D/R Rate: 60%	H1/H2 32mm/32mm D/R Rate: 100%	H1/H2 33mm/33mm D/R Rate: 60%
High Rate	H1/H2 24mm/24mm D/R Rate: 80%	H1/H2 32mm/32mm D/R Rate: 100%	H1/H2 41mm/41mm D/R Rate: 80%

Remote Control EXP Setting Suggestion

1. Aileron EXP curve is shown as below :

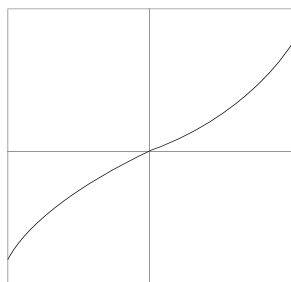

Futaba brand Remote Control : EXP A -30
EXP B -30

Spektrum brand Remote Control : EXPO 30% 30%

2. Elevator EXP curve is shown as below :

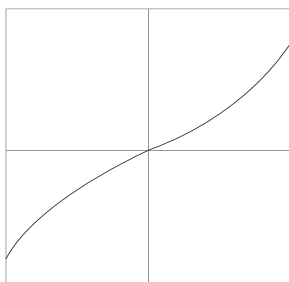

Futaba brand Remote Control : EXP A -30
EXP B -30

Spektrum brand Remote Control : EXPO 30% 30%

3. Rudder EXP curve is shown as below :

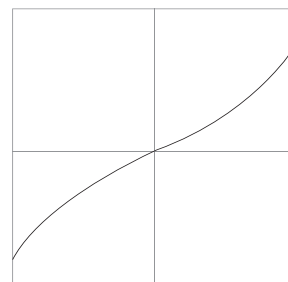

Futaba brand Remote Control : EXP A -30
EXP B -30

Spektrum brand Remote Control : EXPO 30% 30%

Center position of aileron

1. Please refer to the following figure and adjust the aileron to the correct center position

The aileron (outer side) center position is shown in the following figure:

When the endpoint A and the adhesive line B of the fuselage are kept in the same horizontal, the aileron is in the center position.

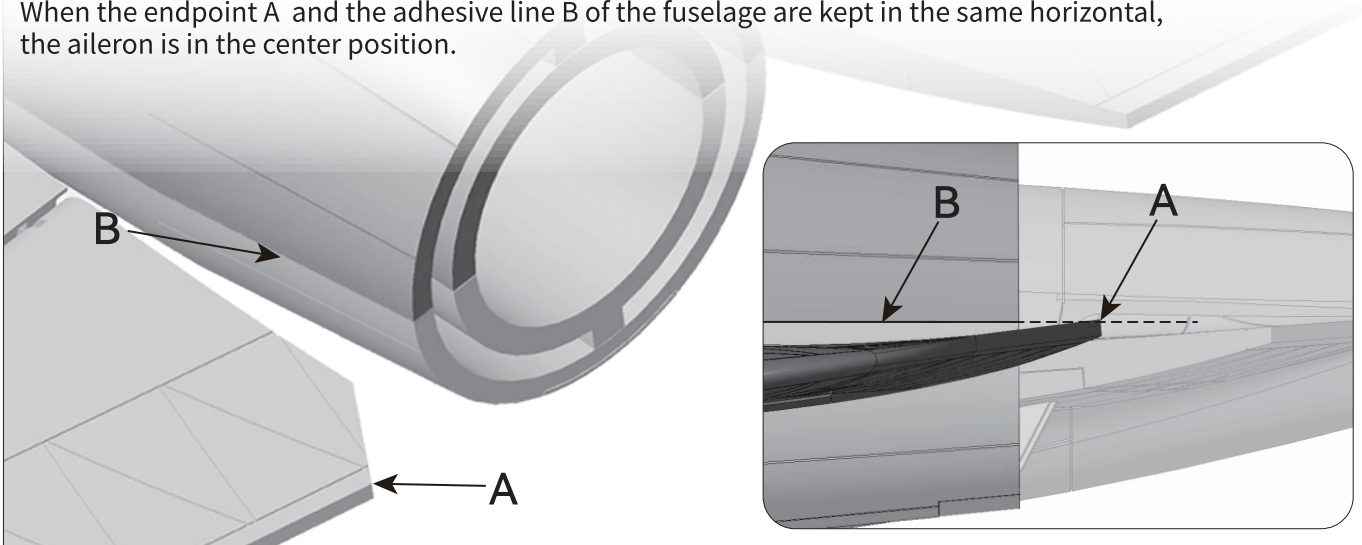

The aileron (in side) center position is shown in the following figure:

Looking from the bottom, align the inside aileron and the raised surface of fuselage, with no height difference, and the inside aileron is in the center position

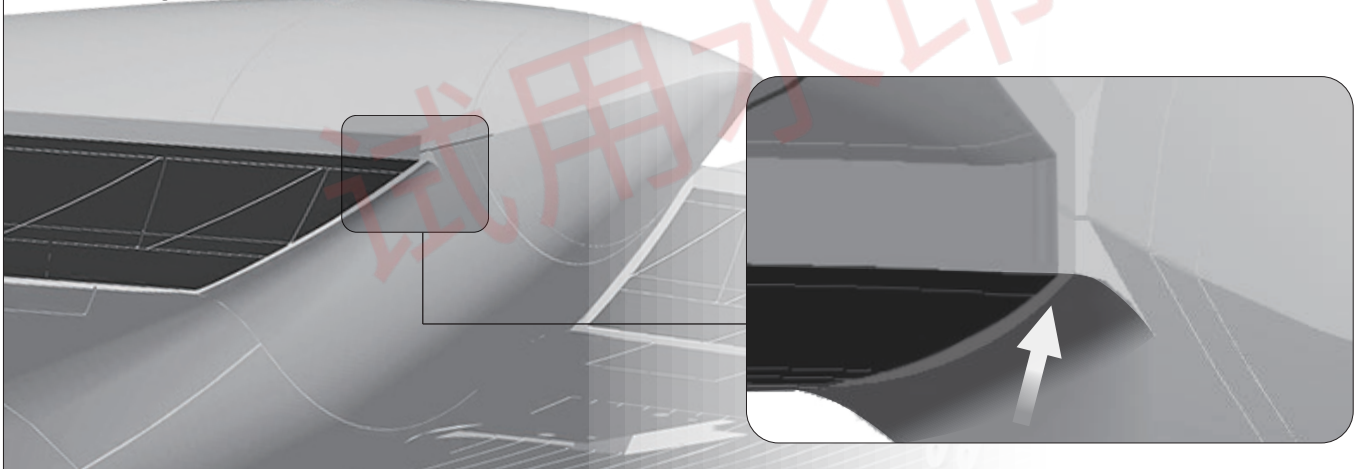

2. The aileron (outer side) should be higher 2~3mm than the aileron (in side).

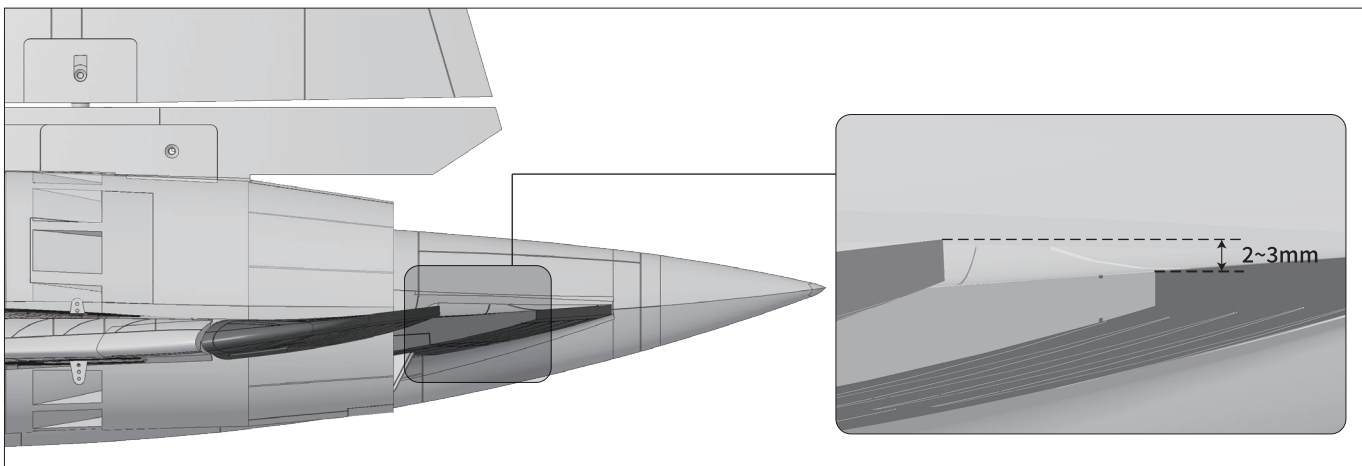

Servo Direction

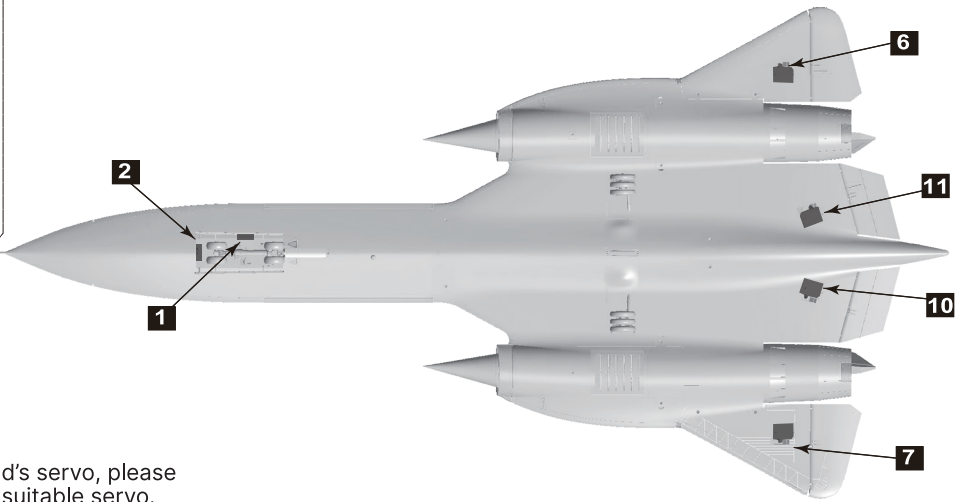
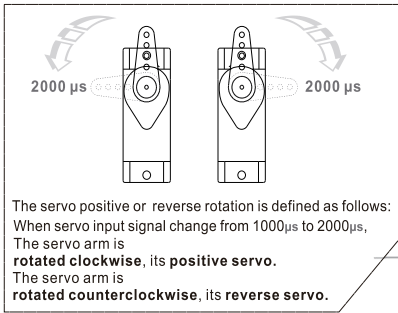

If you need to purchase another brand's servo, please refer to the following list to choose a suitable servo.

Position	Servo regulation	No.	Pos. / Rev.	Cable length
Nose gear steering servo	9g Digital-Hybrid	1	Reverse	500mm
Nose cabin door	9g plastic servo	2	Reverse	600mm
rear cabin door (R)	9g plastic servo	3	Positive	100mm
rear cabin door (L)	9g plastic servo	4	Reverse	100mm
parachute	9g Digital-Hybrid	5	Positive	100mm
Aileron (Outer-side,L)	17g Digital-MG	6	Positive	200mm
Aileron (Outer-side,R)	17g Digital-MG	7	Positive	200mm
Rudder(L)	23g Digital-MG	8	Positive	100mm
Rudder(R)	23g Digital-MG	9	Positive	100mm
Aileron (In-side,L)	17g Digital-MG	10	Positive	100mm
Aileron (In-side,R)	17g Digital-MG	11	Positive	100mm

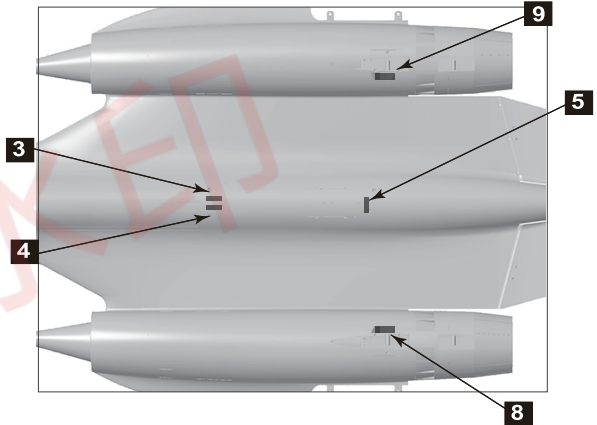

Motor Specification

Item No.MI029571
 2957-2210KV

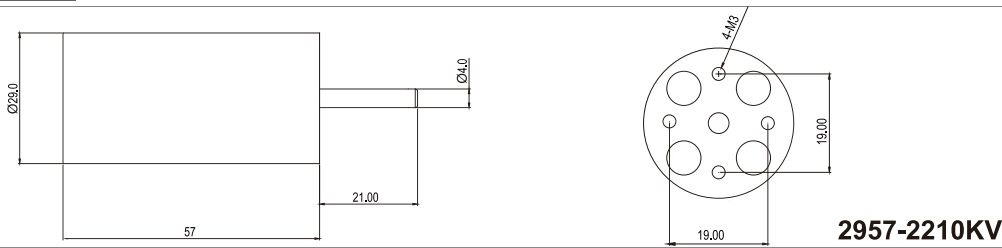

2957-2210KV

Item No.	Motor size	Motor(KV)	Thrust(g)	Current(A)	Use Voltage (V)	Use ESC (A)	EDF Weight (g)	Max power (W)	Efficiency (g/w)
E7218	2957-2210KV	2210KV	2600	70	22.2 (6S)	80	240	1550	1.68

